

Electron Spin Resonance and CIDNP Studies on 1,3-Cyclopentadiyls. A Localized 1,3 Carbon Biradical System with a Triplet Ground State. Tunneling in Carbon-Carbon Bond Formation^{1,2}

S. L. Buchwalter and G. L. Closs*

Contribution from the Department of Chemistry, The University of Chicago, Chicago, Illinois 60637. Received June 19, 1978

Abstract: When matrix isolated 2,3-diazabicyclo[2.2.1]heptene-2 is photolyzed at 5.5 K a strong ESR signal can be observed describable by a triplet state spin Hamiltonian with zero-field splitting parameters $D/hc = 0.084$ and $E/hc = 0.0020 \text{ cm}^{-1}$. The spectrum is attributed to the diradical 1,3-cyclopentadiyl. Several methyl-substituted derivatives also showed ESR spectra. The decay kinetics of the signals are temperature independent from 1.3 to 20 K suggesting a tunneling process. From the kinetics the barrier height for the formation of bicyclopentane is estimated as $2.3 \pm 0.2 \text{ kcal/mol}$. The triplet ground state of the diradical is inferred from the temperature dependence of the ESR spectra as well as from CIDNP experiments at room temperature.

Short-chain biradicals are among the most frequently postulated intermediates in organic reaction mechanisms. In spite of their importance in mechanistic chemistry our actual knowledge of the properties of these intermediates is almost exclusively derived from theoretical calculations. This is especially true for trimethylene and tetramethylene, the simplest members of 1,3 and 1,4 localized biradicals.³ Considering that, because of the inherent approximations, quantum-mechanical calculations are sometimes found to be at variance with experimental results, it certainly would be highly desirable to have direct experimental data on simple biradicals.

An important question has been whether or not the singlet biradical actually corresponds to a secondary minimum on the energy surface, i.e., whether or not the biradical requires an activation energy for ring closure. This activation energy, the Benson barrier,⁴ has not been found by theoretical calculations⁵ nor by stereochemical studies,⁶ both of which tend to support the concept of the biradical as the transition state on an energy surface lacking a secondary minimum. A second, equally important, question is concerned with the role played by the triplet biradical. A number of delocalized biradicals (see Table I) have been observed as long-lived triplets by electron spin resonance (ESR), and, in all but one⁷ of these cases, the triplet has been identified as the ground state of the biradical. No localized 1,3-biradical has ever been detected, however, suggesting that delocalization was causing a large perturbation in the properties of the biradical. We report herein our study of triplet 1,3-cyclopentadiyl and some of its derivatives, the first short-chain localized biradicals to be observed, and discuss the implications of our work on the questions outlined above.

Results

When 2,3-diazabicyclo[2.2.1]heptene-2 (**1**) is irradiated in a glassy matrix of cyclohexane at 5.5 K the strong ESR spectrum shown in Figure 1 is obtained. Other matrices such as pentane-isopentane-*n*-octane gave similar spectra, as gave a microcrystalline powder of **1**. From the appearance of the

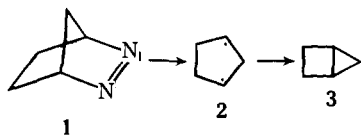

spectrum it is clear that it arises from a molecule with triplet spin multiplicity superimposed on a strong signal from a doublet state which gives rise to the center line. Both the $\Delta m = 1$ and $\Delta m = 2$ transmissions show substantial hyperfine

splitting which could arise from coupling with protons and nitrogen nuclei. The removal of this splitting by perdeuteration (Figure 1, lower trace) rules out a biradical derived from one-bond cleavage of **1** leaving 1,3-cyclopentadiyl (**2**) as the logical alternative. The spectrum of the perdeuterated compound (**1-d₈**) shows resolved *x-y* transitions and the spectrum can be fitted to the triplet state spin Hamiltonian with zero field splitting parameters of $|D/hc| = 0.084$ and $|E/hc| = 0.0020 \text{ cm}^{-1}$.

Comparison of these values with parameters of previously observed organic triplet biradicals (Table I) shows that *D* is larger in **2** than in all but one of the others, that one having considerable carbene character. This is, of course, consistent with the localized character of **2**. In an idealized planar structure of **2**, with bond lengths of 1.54 Å and a bond angle of 110° at the carbon atom separating the radical sites, the distance between the two trigonal carbon atoms is 2.49 Å. Calculation of the zero-field splitting parameters by interpolation of the two-center interactions as suggested by van der Waals and Ter Maten⁸ yields $D/hc = -0.106$ and $E/hc = 0.0055 \text{ cm}^{-1}$. While the agreement with the experimental numbers is only fair, it certainly can be reconciled with **2** being the carrier of the spectrum. It appears likely that distortion from the planar structure is the cause for the discrepancy.

Although the spectrum derived from **1-h₈** shows substantial hyperfine splittings, it was not possible to extract a unique set of hyperfine coupling constants from the spectrum because of insufficient resolution. Also, the fine structure and hyperfine structure tensors have presumably different axis systems making it impossible to obtain the principal components of the hyperfine tensors from the powder spectrum.

The strong central line due to a radical is generated in a secondary photoprocess. This fact was ascertained by the following sets of experiments. Compound **1** was irradiated for 15 s, which was sufficient to generate a detectable triplet signal. No radical signal could be seen, nor could it be detected when the triplet was allowed to decay by warming the matrix to 40 K. When the azo compound was irradiated at 50 K, at which no triplet could be observed, the radical peak was not seen either. Only under prolonged irradiation (1 min or more) at 5.5 K could the radical be observed, and then it grew in intensity continuously and did not decay on warming to 50 K. The radical signal consists of eight resolved hyperfine lines (Figure 2, upper half) closely resembling the published solid-state spectrum attributed to cyclopentyl radicals.⁹ Based on these observations it appears that the photoexcited biradical abstracts hydrogen from the matrix yielding cyclopentyl radical

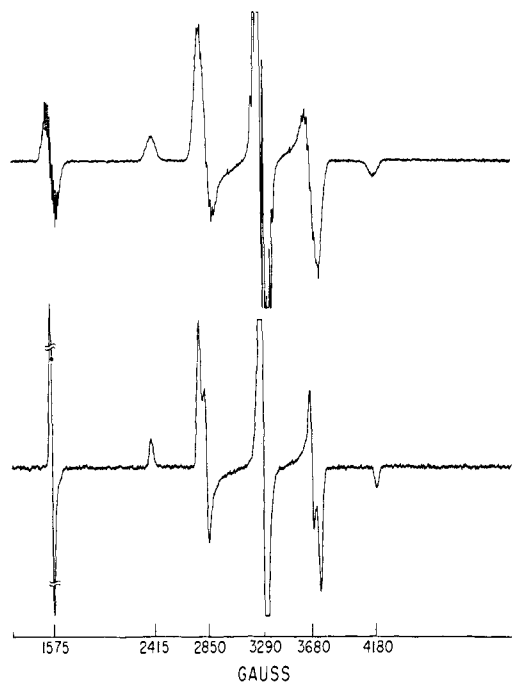

Figure 1. ESR spectra obtained upon irradiation of a cyclohexane matrix containing **1** (upper trace) and **1-d₈** (lower trace) at 5.5 K.

Table I

biradical	$ D $, cm ⁻¹	$ E $, cm ⁻¹	ref
	0.024	0	<i>a</i>
	0.1069	0.0058	<i>b</i>
	0.068	0.003	<i>c</i>
	0.027	0.0023	<i>d</i>
	0.0204	0.0016	<i>e</i>
	0.018	<0.003	<i>f</i>
	0.084	0.0020	<i>g</i>

^a P. Dowd, *J. Am. Chem. Soc.*, **88**, 2587 (1966). ^b G. L. Closs, L. R. Kaplan, and V. I. Bendall, *ibid.*, **89**, 3376 (1967). ^c D. R. Arnold, A. B. Evin, and P. H. Kasai, *ibid.*, **91**, 784 (1969). ^d J. A. Berson, R. J. Bushby, J. M. McBride, and M. Tremelling, *ibid.*, **93**, 1544 (1971). ^e W. R. Roth and G. Erker, *Angew. Chem., Int. Ed., Engl.*, **12**, 503 (1973). ^f R. M. Pagni, C. R. Watson, Jr., J. E. Boor, and J. R. Dodd, *J. Am. Chem. Soc.*, **96**, 4065 (1974). ^g This work.

and the matrix-derived radical. This scheme is supported by the change of radical spectrum upon perdeuteration of **1**. Most of the hyperfine splitting is eliminated but not all and presumably the residual splittings are due to the matrix-derived radical (Figure 2, lower trace).

The decay of the triplet signal showed highly unusual behavior. First, the decay kinetics are nonexponential. An ex-

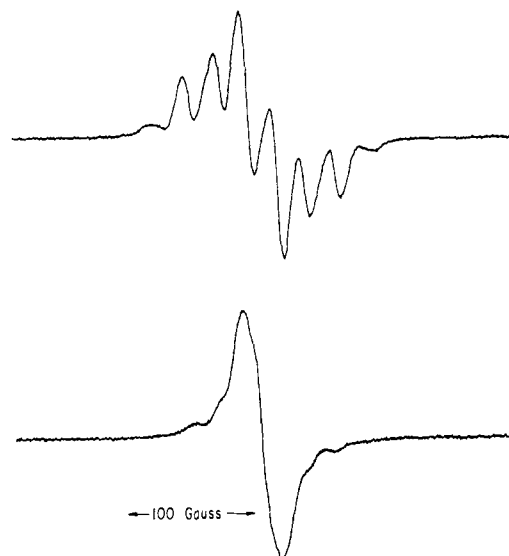

Figure 2. Spectrum of the $g = 2$ signal obtained upon irradiation of a cyclohexane matrix containing **1** (upper trace) and **1-d₈** (lower trace) at 5.5 K.

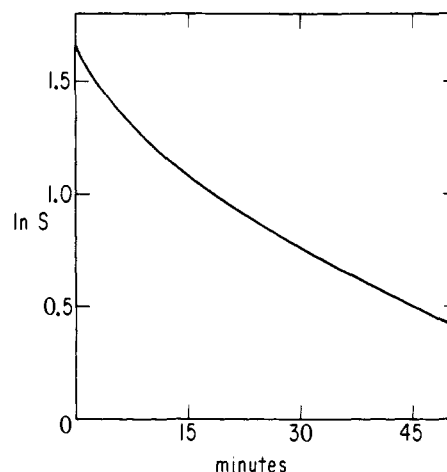

Figure 3. Example of the nonexponential decay of the triplet signal obtained by irradiating **1** isolated in a cyclohexane matrix at 5.5 K.

ample of this is shown in Figure 3. Second, curves obtained at 5.3–20 K exhibited no temperature dependence. The initial rate constant in each case was about $5 \times 10^{-4} \text{ s}^{-1}$ and dropped by a factor of 3 over the time of the experiment (1 h). The triplet spectrum was also detected at 1.3 K and dark decay was observed at qualitatively the same rate. There is ample precedence for nonexponential decay in matrices.¹⁰ The most probable cause is a distribution of different sites. Since the decay of the triplet state is certainly associated with substantial nuclear displacements, a random distribution of different matrix sites will have an effect on the decay rates. It should be noted that this behavior was not restricted to cyclohexane matrices but was found for all matrices investigated. The rates varied somewhat for different matrices but qualitatively the behavior was the same.

The lack of temperature dependence of the triplet decay is highly suggestive for a tunneling process. This suggestion is further strengthened by the behavior of the perdeuterated derivative of **2**. In this case the triplet signal decayed less than 20% on the time scale of the experiment up to temperatures of 25 K. Above that, faster decay set in and was again found to be nonexponential.

The nonexponential decay characteristics prevented an accurate kinetic study. Nevertheless, highly useful information

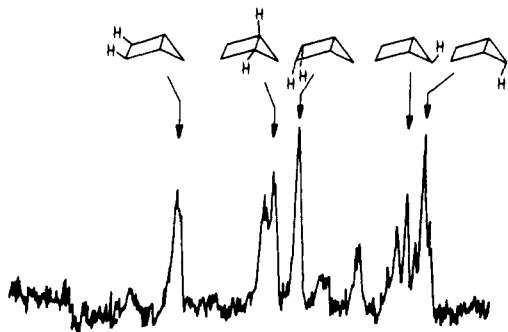

Figure 4. 90-MHz NMR spectrum obtained on benzophenone-sensitized photolysis of $1-d_2$ and its assignments (upper trace). For comparison a dark spectrum taken after the photolysis is shown in the lower trace. The two strong peaks in the center are from unphotolyzed 1 .

can be obtained from initial decay rates which are listed in Table II.

The question arises what product the triplet state decays to. It is well-known that the major product of room temperature photolysis is bicyclo[2.1.0]pentane (3) with a small amount of cyclopentene as a byproduct.¹¹ Since this does not necessarily imply that bicyclopentane is the product at these low temperatures the reaction mixtures were analyzed by GLC. Samples photolyzed at 5.5 K in a cyclohexane matrix were found to contain bicyclopentane and cyclopentene in a ratio of 30:1. Room temperature photolysis of 1 yielded the same compounds in a somewhat smaller ratio, $\sim 25:1$. This strongly suggests that the triplet decay product at the low temperatures is bicyclopentane, because, if the tunneling process involved a 1,2-hydrogen shift to give cyclopentene, this product should be enriched at very low temperatures where the reaction can no longer proceed over the top of the barrier. A perhaps equally strong argument for bicyclopentane as the reaction product from triplet 2 arises from the analysis of the rate data presented in Table II and examined in the Discussion section.

The decay of the ESR signals prevented a measurement of the signal intensity as a function of temperature. Such a Curie plot would have given information on whether the triplet state of 2 is the ground state. However, the triplet signals were observed in an experiment at a temperature as low as 1.3 K, strongly suggesting the triplet state as the ground state of 2 . More convincing evidence that this is true is obtained from NMR experiments at elevated temperatures.

The technique of chemically induced dynamic nuclear polarization (CIDNP) can give very useful information on reactions proceeding via biradicals.¹² Among them is the information on the spin multiplicity of the biradical precursor of the diamagnetic reaction product. In the case of biradicals this arises from the predominant mixing of either the lower or the upper Zeeman level in triplet state with the singlet level which occurs when the singlet or the triplet is the ground state, respectively. Since in the two cases the signals are of opposite sign, such an experiment is really quite unambiguous. How-

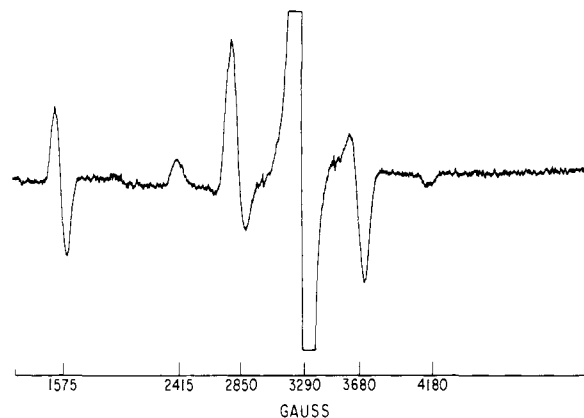

Figure 5. ESR spectrum obtained upon irradiation of a cyclohexane matrix containing 4 at 5.5 K.

Table II. Initial Rates of Decay of the $\Delta m = 2$ Line (1575 G) of the ESR Spectrum Obtained on Photolysis of 1 in a Cyclohexane Matrix







T	$1/T$	$\ln k, s^{-1}^a$
5.50	0.182	-7.39 ± 0.5
6.14	0.163	-7.35 ± 0.5
9.35	0.107	-7.59 ± 0.5
13.16	0.076	-7.63 ± 0.5
21.28	0.047	-7.82 ± 0.5
30.30	0.033	-6.76 ± 0.5
35.71	0.028	-6.24 ± 0.5
40.00	0.025	-5.84 ± 0.5

^a Errors are estimates obtained from spread of values measured for several runs at the same temperature.

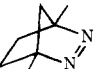
ever, it is necessary to know the multiplicity of the biradical precursor to make the assignment. This can be assured by running the reaction via photosensitization, choosing a known triplet sensitizer. Such experiments were carried out with 1 and were successful. When solutions of 1 in deuteriobenzene containing benzophenone were irradiated in a probe of a 90-MHz NMR spectrometer all proton transitions in bicyclopentane were observed in enhanced absorption. To make an unambiguous assignment of the transitions, the experiment was repeated with *exo*-5,6-dideuterio-2,3-diazabicyclo[2.2.1]heptene-2 ($1-d_2$). In this case the overlap of resonances of starting material and product was minimized. The spectrum obtained with its assignments is shown in Figure 4. Since both dideuteriobicyclopentane isomers were formed it was possible to detect polarizations at all proton resonances. The important point here is that all proton transitions are in enhanced absorption, although the signs of the hyperfine coupling constant of protons α and β to the radical sites are expected to be different. This establishes that the mechanism of polarization is predominantly that of the T_+-S mixing type, implying a biradical precursor of 3 and establishing its ground state to be a triplet state. Of course, this conclusion is based on the assumption that the biradical was formed in its triplet state. To establish that this is true a control experiment was run in which no sensitizer was added. No polarization was observed in line with expectations for triplet sensitization.

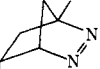
A number of substituted analogues of 1 were prepared and photolyzed at 5.5 K, and the ESR results are summarized in Table III. The intensity of the triplet ESR spectrum was markedly reduced or eliminated completely by the substitution. For example, the compound with one bridgehead methyl group (4) gives the spectrum shown in Figure 5 but addition of a second methyl as in $7-9$ caused no spectrum to be observed. The decay behavior of the signal from 4 was similar to that

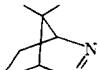
Table III. ESR Results

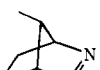
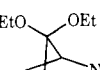
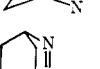
$S/N > 2$		no triplet ESR spectrum	
	1		7
	4		8
	5		9
	6		10
			11
			12

obtained from **1**, although somewhat slower. CIDNP studies on the derivatives of **1** were more ambiguous because there was substantial overlap of the signals from the starting azo compounds with the hydrocarbon products. Definite polarization was observed in the sensitized photolysis of compounds **9** and **10**, although neither gave an ESR spectrum at low temperature. Finally it is of interest that no triplet ESR spectrum could be obtained from the photolysis of the homologous system, 2,3-diazabicyclo[2.2.2]octane-2 (**12**). NMR studies were also unsuccessful.

Discussion

The photochemistry of **1** has been studied quite extensively by several groups.¹³ The quantum yields of both the direct and sensitized decomposition approach unity, but quenching studies indicate that in the direct photolysis decomposition occurs dominantly from the excited singlet state of the azo compound.

The NMR results of this study are consistent with this conclusion since polarization is not observed in the absence of a sensitizer. The ESR observation of **2** from direct photolysis of **1** requires that intersystem crossing must occur at some point, however. It should be noted in this regard that it is likely that only a small fraction of decomposed **1** gives **2**. An experimental determination of this fraction was not feasible because of the instability of **2**. But a semiquantitative estimate shows that the ratio of **2** observed and **1** decomposed is less than 0.1. It seems probable, therefore, that a minor pathway for photolysis of **1** involves, at least under the conditions of the ESR experiment, decomposition from the triplet excited state of **1** to give triplet **2**. That this should be more pronounced at very low temperatures is not unexpected if there is a small activation energy associated with the decomposition of singlet **1**.

Perhaps the most interesting result in this study is the decay kinetics of the triplet signal attributed to **2**. Figure 6 shows the Arrhenius plot for the initial decay rates listed in Table II. The virtual temperature independence up to 20 K must be due to tunneling. We therefore have to write the rate expression with a tunneling correction factor Q which is, among other variables, a function of temperature.

$$k = Q A e^{-E/RT}$$

A and E are the normal Arrhenius parameters. Before we can

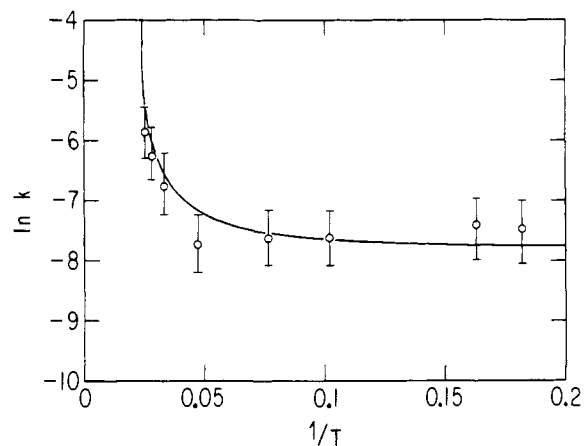

Figure 6. Arrhenius plot of the initial decay rates of **2** in a cyclohexane matrix. The solid line is the component best fit using the parameters listed in Table IV.

estimate the tunneling contribution to the rate it is necessary to estimate the magnitude of A . This factor will deviate substantially from the normal preexponential factor of a unimolecular reaction because of the spin multiplicity change associated with the reaction. Fortunately, it is possible to make an order of magnitude estimate for A based on the NMR results. The fact that CIDNP is observed at all shows that the hyperfine interaction contributes substantially to the intersystem crossing mechanisms. At least any other interaction such as spin-orbit coupling cannot be much larger. Since hyperfine interactions are of the order of 10^8 rad/s the maximum intersystem crossing rate can be 10^8 s⁻¹. However, this requires a perfect match of singlet and triplet energies. In fact this is never the case in small biradicals and one can expect the rate to be substantially slower. It appears from flash photolysis work that the lifetime of some triplet 1,3 biradicals is of the order of 10^{-7} s.¹⁴ If we adopt this value for the rate of collapse of **2** at room temperature we obtain an A factor of 10^8 s⁻¹ for an activation energy of 2.3 kcal/mol.¹⁵ The latter value is obtained from the region between 20 and 40 K where the reaction begins to become temperature dependent. To reproduce the temperature dependence we have to adopt a model for the tunneling calculations. The simplest model for an order of magnitude calculation is that first developed by Bell involving a parabolic barrier of width $2a$ and heights E .¹⁶ With this barrier the expression for Q is

$$Q = \frac{e^\alpha}{\beta - \alpha} (\beta e^{-\alpha} - \alpha e^{-\beta})$$

where

$$\alpha = E/RT$$

and

$$\beta = 2\pi^2 a (2mE)^{1/2} / h$$

Here m is the mass of the tunneling particle. Some ambiguity exists of what to take for m . In case of hydrogen tunneling to give cyclopentene m is clearly defined as the mass of the hydrogen atom, but this is not so for bicyclopentane formation. Here we have a bending vibration taking the planar or nearly planar biradical to the bicyclic hydrocarbon. This process may be approximated by the out-of-plane motion of the CH₂ group. Using the parameters listed in Table IV a best fit to the experimental points was calculated and is shown as the solid line in Figure 6. It is noteworthy that the barrier height of 2.3 kcal is almost independent of what other parameters are chosen for the tunneling calculation. In order to get the curvature of the plot to occur where it does, E has to have the value given. Also,

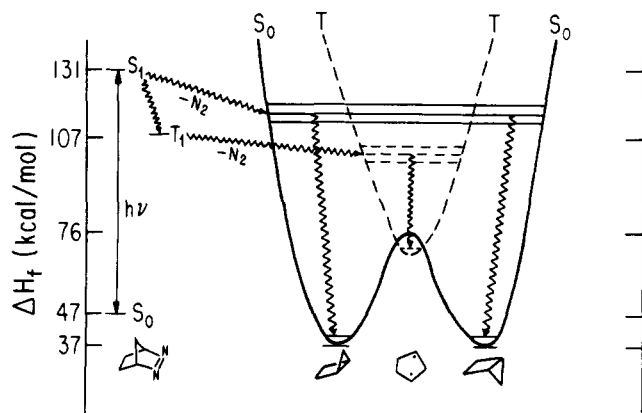

Figure 7. Energy diagram of **1**, **2**, and **3**. The curvatures of the potential curves are schematic.

it is not possible to make the rate data fit for hydrogen shift to give cyclopentene. The much lower mass has to be compensated for by a corresponding increase in barrier width. To obtain the observed rate the barrier width has to be 2.4 Å, a much larger distance than the migration pathway. To summarize the tunneling analysis it can be stated that the observed rate behavior is consistent with the tunneling of 1,3-cyclopentadiyl to give bicyclopentane and the barrier height can be fixed quite unambiguously at 2.3 ± 0.2 kcal/mol. Owing to the crudeness of the model, the other parameters, such as the width of the barrier and the A factor, have considerably larger uncertainties.

The unambiguous observation of tunneling in organic reactions is quite rare. While in the reaction described here tunneling is the sole pathway at temperatures below 20 K, its contribution at room temperature of course is negligible (~ 1 part in 10^{11}).

The reaction sequence $1 \rightarrow 2 \rightarrow 3$ can be placed on a quantitative basis by taking advantage of data appearing in the literature. The heats of formation of **1** (+47 kcal/mol)¹⁷ and **3** (+37 kcal/mol)¹⁸ have both been measured, and the energies of the excited singlet and triplet states of **1** (84 and 60 kcal/mol, respectively)¹³ are also known. These points have been placed on an energy diagram in Figure 7. The energy of activation for the ring inversion of 2-methylbicyclopentane (39 kcal/mol)¹⁹ has been determined, and, if there is no secondary minimum on the lowest singlet surface of bicyclopentane, the heat of formation of a ring-opened species, as is done in Figure 7 (the data in Figure 7 are for the gas phase in 298 K and not for the conditions of the ESR experiments, but, to a great extent, the relative energies will of course be the same).

The data in Figure 7 show that the triplet state of **1** lies about 31 kcal/mol above the singlet ring-opened species. Since the energy of the triplet biradical will not differ by much from that of the singlet species, it is clear that the azo triplet has more than enough energy to populate vibrational levels of the triplet biradical. Moreover, it is likely that the nitrogen molecule will be expelled with sufficient energy that further interaction with the hydrocarbon fragment will be nil.

Figure 7 shows the triplet as the ground state of the biradical. The justification for this conclusion rests on three points. First, the enhanced absorption observed in the NMR experiments is consistent with a ground triplet state. Second, the ESR spectrum of **2** could be observed even at 1.3 K. Third, the irreversible decay of the spectrum is many orders of magnitude too slow to be caused by radiationless decay from a triplet lying just above the ground singlet surface. Thus, it is likely that triplet **2** is the ground state at the planar geometry, but that only a bending vibration is necessary to carry it to a geometry

Table IV. Activation and Tunneling Parameters Used to Compute the Curve Shown in Figure 6

preexponential factor	A	10^8 s^{-1}
barrier height	E	$1.6 \times 10^{-13} \text{ erg}$ (2.3 kcal/mol)
barrier width	$2a$	$0.64 \times 10^{-8} \text{ cm}$
mass of tunneling particle	m	$2.324 \times 10^{-23} \text{ g}$ (14 mass units)

at which the singlet surface is lower (see below). The observation of cyclopentadiyl as a ground-state triplet indicates that delocalization is not necessary for the observation of short-chain biradicals.

The question of whether or not a secondary minimum exists on the lowest singlet surface warrants discussion. A comparison of the experimentally derived heat of formation of the transition state for the ring inversion of bicyclopentane (76 kcal/mol)^{18,19} to the thermochemical estimate of the heat of formation of the biradical (67 kcal/mol)^{4,20} indicates that such a minimum would be 9 kcal/mol deep. Such a barrier would hardly seem to be consistent with the instability of the triplet biradical, having as it does the spin forbiddenness as an extra retarding factor for ring closure. Our evidence is not sufficient to rule out a small dip in the singlet surface, but the simplest hypothesis at this point is that no such minimum exists.

Finally, it should be pointed out that a consequence of this analysis is that successful matrix isolation and spectroscopic observation of biradicals of the type investigated are only possible when the triplet surface intersects the singlet surface as shown in Figure 6. If the triplet state were of higher energy at all configurations of the biradical, radiationless decay would convert it to the singlet which will smoothly decay to the reaction product. The relative ordering of states may well be the cause of the failure to observe a biradical derived from **12** and from 1-pyrazoline and its derivatives.

Experimental Section

2,3-Diazabicyclo[2.2.1]hept-2-ene (1). The literature procedure²¹ was followed, the product being purified by sublimation. For purposes of comparison, the spectral data are given: NMR (CDCl₃) δ 5.0 (s, 2 H), 8.50 (m, 2 H), 0.63 (m, 2 H); IR (CCl₄) $\nu_{\text{N}=\text{N}}$ 1445, 1495 cm^{-1} ; λ_{max} (cyclohexane) 340 nm (ϵ 420).

exo,exo-4,5-Dideuterio-2,3-diazabicyclo[2.2.1]hept-2-ene. This specifically labeled material was prepared, following Roth and Martin,²² by substituting molecular deuterium for hydrogen at the appropriate place in the synthesis of the unlabeled compound.

2,3-Diazabicyclo[2.2.1]hept-2-ene-*d*₆. Cyclopentadiene-*d*₆²³ was used as the starting material for the above synthesis (again using molecular deuterium) to obtain a sample of the perdeuterio compound (>99% deuterium by NMR using 99.8% CDCl₃ as standard).

7,7-Dimethyl-2,3-diazabicyclo[2.2.1]hept-2-ene. 5,5-Dimethylcyclopentadiene²⁴ (2 g, 0.02 mol) was added to an ethyl acetate solution of *N*-phenyltriazolinediiron (PTAD,²⁵ 3.9 g, 0.02 mol). Concentration of the solution yielded 4.2 g of crystalline adduct, which was recrystallized from ethyl acetate to yield 3.6 g of pure material. This material was then stirred overnight in 20 mL of ethyl acetate under hydrogen with 15 mg of PtO₂ catalyst. After filtration and evaporation, a quantitative yield of white, crystalline product was obtained, which was free of olefin by NMR. A 2.9-g portion (0.011 mol) of this hydrogenated material was added to a hot (165–170 °C) solution of 4 g of KOH in 10 mL of ethylene glycol. Nitrogen was bubbled through the basic glycol for 20 min prior to the addition and was continued during the 30-min heating period following the addition. After the turbid reaction mixture had cooled to room temperature, it was diluted with 5–10 mL of water and extracted with six 20-mL portions of ether. The combined extracts were dried with MgSO₄, filtered, and concentrated to the rotary evaporator. The concentrate, dissolved in 50 mL of water, was then added to a magnetically stirred solution of 10 g of CuCl₂·2H₂O and 1.3 mL of 3 N HCl in 135 mL of water. The red complex was collected by filtration and washed with a little water, ethanol, and ether. The complex was then hydrolyzed by adding it to a 50 mL of concentrated aqueous ammonia. The blue aqueous solution was then extracted with six 50-mL portions of ether. The dried and

filtered extracts were concentrated by distillation through a column of glass helices. The last few milliliters of solvent were removed with a stream of nitrogen. The solid residue was then sublimed at 50 °C and 15 mm to yield 700 mg (53% based on the hydrogenated adduct) of white crystals (mp 43–43.5 °C), identified as 7,7-dimethyl-2,3-diazabicyclo[2.2.1]hept-2-ene: NMR (CDCl₃) δ 4.67 (s, 2 H), 1.8 (m, 2 H), 1.00 (s, 3 H), 0.9 (m, 2 H), 0.77 (s, 3 H); IR (CCl₄) ν_{N=N} 1473, 1491 cm⁻¹; λ_{max} (cyclohexane) 346 nm (ε 161).

Photolysis and Pyrolysis of 7,7-Dimethyl-2,3-diazabicyclo[2.2.1]hept-2-ene. A 112-mg sample of the dimethyl azo compound was dissolved in 2.4 mL of benzene-d₆. Aliquots (400 μL) of this solution were placed in four NMR tubes. The samples were degassed three times and then sealed under vacuum. One sample was irradiated with a medium-pressure mercury lamp for 30 min, which was nearly sufficient to decompose all of the starting material (by NMR). Two other samples were heated at 6 and 30 min in refluxing decalin (~°C). The 6-min sample had just detectable product, but the 30-min sample was ~15% decomposed, giving a rough first-order rate constant of 10⁻⁴ s⁻¹, which is within an order of magnitude of that of the parent compound.²⁶ Neither the photolysis nor the pyrolysis caused any olefinic absorptions to appear in the NMR, and the NMR spectrum of the product was wholly consistent with the structure, 5,5-dimethylbicyclo[2.1.0]pentane: NMR (C₆D₆) δ 1.95 (m, 2 H), 1.39 (m, 2 H), 1.29 (m, 2 H), 1.16 (s, 3 H), 0.89 (s, 3 H).

7-Methyl-2,3-diazabicyclo[2.2.1]hept-2-enes. A THF solution of 5-methylcyclopentadiene was prepared by an adaptation of the procedure of McLean and Haynes.²⁷ Sodium cyclopentadienide was made by adding freshly distilled cyclopentadiene (16.5 g, 0.025 mol) to an equimolar amount of sodium (5.8 g, 0.25 g-atom) in a 500-mL three-necked flask. A nitrogen atmosphere was maintained during the addition. The addition caused the solvent to reflux gently; mechanical stirring was used during the addition and for 60 min afterwards. The reddish mixture was siphoned through a plug of glass wool into a large addition funnel, the nitrogen atmosphere being maintained. The sodium cyclopentadienide solution was then added slowly to ca. 50 g of dimethyl sulfate, mechanically stirred in a bath of acetone at -10 to -20 °C. Thirty minutes after the addition was complete, the stirrer was removed and replaced with a stopper, and a vacuum pump was attached to the flask by way of two dry ice-acetone traps. The solvent and volatile products were allowed to distill over without heating. After 2.5 h, distillation appeared to be finished. The first trap contained 110 mL of colorless distillate.

The cold THF solution of 5-methylcyclopentadiene was then quickly added to an ice-cold solution of PTAD (1.8 g, 0.10 mol) in ethyl acetate until the characteristic red color of PTAD disappeared. The remaining THF solution was stored in the freezer (see below). The adduct mixture, after evaporation of the solvents, was hydrogenated and hydrolyzed by the procedure given above for the dimethyl compound. The final purification was effected by preparative gas chromatography (GC) (20% SE-30 on Chromosorb W, 5 ft × 0.25 in., 60 mL/min He, 100 °C) of the concentrated extract, yielding small samples of the two epimeric 7-methyl-2,3-diazabicyclo[2.2.1]hept-2-enes (bath oils) in ca. 3:1 ratio. The epimer in excess is assumed to have the methyl group oriented anti to the azo linkage, based on the relative ease of attack of the dienophile to give this isomer. The NMR data confirm this assignment. Anti: NMR (CDCl₃) δ 5.00 (s, 2 H), 1.6 (m, 3 H), 0.90 (m, 2 H), 0.62 (d, 3 H); IR (neat) ν_{N=N} 1460, 1494 cm⁻¹. Syn: NMR (CDCl₃) δ 4.81 (s, 2 H), 1.64 (m, 3 H), 0.97 (m, 2 H), 0.87 (d, 3 H).

1- and 5-Methyl-2,3-diazabicyclo[2.2.1]hept-2-enes. The THF solution of 7-methylcyclopentadiene was allowed to equilibrate²⁷ for 24 h at room temperature. After treating it with PTAD, the mixture was then subjected to the above-described three-step procedure to yield a mixture of two products, small amounts of which were isolated as oils by GC. They were identified by NMR as 1-methyl-2,3-diazabicyclo[2.2.1]hept-2-ene [NMR (CDCl₃) δ 5.08 (s, 1 H), 1.86 (s, 3 H), 1.64 (m, 2 H), 1.43 (m, 1 H), 1.12 (m, 2 H), 0.93 (m, 1 H); IR (neat) ν_{N=N} 1452, 1497 cm⁻¹] and 5-methyl-2,3-diazabicyclo[2.2.1]hept-2-ene [NMR (CDCl₃) δ 5.13 (s, 1 H), 5.08 (s, 1 H), 2.08 (m, 1 H), 1.83 (m, 1 H), 1.22 (m, 2 H), 0.83 (d, 3 H), 0.51 (m, 1 H)].

1,4- and 1,5-Dimethyl-2,3-diazabicyclo[2.2.1]hept-2-enes. The procedure of McLean and Haynes^{27,28} was used to prepare a mixture of 1,3- and 1,4-dimethylcyclopentadienes. This mixture was then treated with PTAD and converted to bicyclic azo compounds as above. Isolation of the two products was done by GC to give small samples (oils) of 1,4-dimethyl-2,3-diazabicyclo[2.2.1]hept-7-ene (minor

product) [NMR (CDCl₃) δ 1.83 (s, 6 H), 1.55 (m, 4 H), 1.08 (m, 2 H)] and 1,5-dimethyl-2,3-diazabicyclo[2.2.1]hept-2-ene (major product) [NMR (CDCl₃) δ 4.96 (s, 1 H), 2.09 (m, 1 H), 1.77 (s, 3 H), 1.60 (m, 2 H), 1.14 (m, 2 H), 0.77 (d, 3 H); IR (neat) ν_{N=N} 1456, 1502 cm⁻¹].

7,7-Diethoxy-2,3-diazabicyclo[2.2.1]hept-2-ene. Cyclopentadienone diethyl ketal was prepared by the method of Eaton and Hudson²⁹ and reacted immediately with PTAD. Conversion to the corresponding azo compound was routine except that the Cu complex was unstable to alcohol. The azo compound was isolated as an oil by GC: NMR (CDCl₃) δ 4.99 (s, 2 H), 3.47 (overlapping pair of quartets, 4 H), 1.92 (d, 2 H), 1.13 (overlapping pair of triplets, 6 H), 0.97 (d, 2 H); IR (neat) ν_{N=N} 1455, 1483 cm⁻¹; λ_{max} (CHCl₃) 343 nm.

ESR Experiments. A Varian E-9 spectrometer was equipped with an Air Products and Chemicals Helitran LTD-3-110 liquid helium transfer apparatus and with a 2000-W mercury xenon lamp focused on the microwave cavity. The output from the lamp was filtered with water and Pyrex. The exact temperature at the sample was checked periodically with a calibrated gold (0.7 atom % iron) vs. chromel thermocouple sealed in a sample tube. The usual temperature obtained under optimal conditions of flow was 5.5 K. The temperature was monitored (less accurately) throughout the experiments with another gold-chromel thermocouple located ca. 3 cm below the sample in the Helitran quartz Dewar. Temperatures above the minimum were obtained using the Helitran automatic temperature controller.

Samples were prepared by dissolving the compound to be studied in enough solvent (cyclohexane in most cases) to make a 1% w/v solution. The solutions were placed in 4 mm o.d. quartz tubes, degassed (three freeze-pump-thaw cycles), and sealed under vacuum. Samples were rapidly frozen in liquid nitrogen before being inserted into the sample cavity, which had been precooled to 5.5 K.

Spectra were recorded after 1–2 min of irradiation, the lamp being operated at 1200–1300 W. In most cases, irradiation was continued during the recording of spectra. Decay curves were obtained by irradiation until good signal/noise was obtained and then holding the magnetic field constant at the top of the first derivative peak of the Δmg = 2 transition while scanning over time with the light off. Occasionally, the decay was preceded by a short period of increasing intensity. The field and base line were found to be steady during the time of the decay (16–30 min).

The product mixture on warmup was analyzed by GC on two columns (20% dimethylsulfolane on base-washed Firebrick 9 ft × 0.125 in., 30 °C, and 8% QF-1 on 80/100 Firebrick, 9 ft × 0.125 in., 30 °C). Comparison with the room temperature photolysis mixture and coinjection of cyclopentene showed the only two products to be cyclopentene and bicyclopentane. The amount of cyclopentene from photolysis at either temperature was 3–5% of the bicyclopentane.

NMR Experiments. Samples were prepared by dissolving the azo compound (0.16 mol) and benzophenone (0.16 mol) in 400 μL of CDCl₃. The samples were degassed in standard 5 mm o.d. NMR tubes capped with rubber septa. For irradiation, the output of a 1000-W high-pressure mercury lamp was passed through a quartz water filter into the probe of a Bruker 90-MHz spectrometer. Spectra were recorded using a single pulse before irradiation, during irradiation 5–10 s after the light was admitted, and in the dark at least 2 min after irradiation had been stopped.

References and Notes

- (1) Supported by NSF Grant CHE76-01795 and NSF (GP 33116) and NIH Cancer Center Grant CA 14599, used to purchase the NMR equipment used in this work.
- (2) Part of this work was published as a preliminary communication: S. L. Buchwalter and G. L. Closs, *J. Am. Chem. Soc.*, **97**, 3857 (1975).
- (3) Recently biradicals produced by Norrish type II reactions have been detected by flash photolysis: R. D. Small, Jr., and J. C. Scaiano, *Chem. Phys. Lett.*, **50**, 431 (1977); J. Faure, J. P. Fouassier, D. J. Longnot, and R. Savin, *Nouveau J. Chim.*, **1**, 15 (1977).
- (4) (a) S. W. Benson, *J. Chem. Phys.*, **34**, 521 (1961); (b) R. G. Bergman, "Free Radicals", Vol. I, J. K. Kochi, Ed., Wiley, New York, 1973, Chapter 5; H. E. O'Neal and S. W. Benson, *Int. J. Chem. Kinet.*, **2**, 423 (1970).
- (5) (a) J. H. Horsley, Y. Jean, C. Moser, L. Salem, R. M. Stevens, and J. S. Wright, *J. Am. Chem. Soc.*, **94**, 279 (1972); (b) P. J. Hay, W. J. Hunt, and W. A. Goddard III, *ibid.*, **94**, 638 (1972).
- (6) (a) J. A. Berson and J. M. Balquist, *J. Am. Chem. Soc.*, **90**, 7343 (1968); (b) R. G. Bergman and W. Carter, *ibid.*, **91**, 7411 (1969); (c) R. J. Crawford and T. R. Lynch, *Can. J. Chem.*, **46**, 1457 (1968); (d) W. von E. Doering and K. Lachdev, *J. Am. Chem. Soc.*, **96**, 1168 (1974); (e) J. A. Berson, L. D. Pedersen, and B. K. Carpenter, *ibid.*, **98**, 122 (1976).
- (7) R. M. Pagni, C. R. Watson, Jr., J. E. Bloor, and J. R. Dodd, *J. Am. Chem.*

- Soc., **96**, 4064 (1974).
- (8) J. H. van der Waals and G. Ter Maten, *Mol. Phys.*, **8**, 301 (1964).
- (9) P. B. Ayscough and C. Thomson, *Trans. Faraday Soc.*, **58**, 1477 (1962); T. Ohmae, S. Ohnishi, K. Kulvata, H. Sahural, and I. Nitta, *Bull. Chem. Soc. Jpn.*, **40**, 226 (1967).
- (10) (a) F. Castelli and L. S. Forster, *J. Am. Chem. Soc.*, **97**, 5306 (1975); (b) R. M. Pagni, C. R. Watson, Jr., J. E. Bloor, and J. R. Dodd, *ibid.*, **96**, 4065 (1974); (c) W. G. French and J. E. Willard, *J. Phys. Chem.*, **72**, 4604 (1968); (d) A. Campion and F. Williams, *J. Am. Chem. Soc.*, **94**, 7633 (1972).
- (11) P. S. Engel, *J. Am. Chem. Soc.*, **91**, 6903 (1969).
- (12) G. L. Closs, *Adv. Magn. Reson.*, **7**, 157 (1974).
- (13) (a) B. Solomon, T. F. Thomas, and C. Steel, *J. Am. Chem. Soc.*, **90**, 2249 (1968); W. D. K. Clark and C. Steel, *ibid.*, **93**, 6347 (1971); (b) P. S. Engel, *ibid.*, **91**, 6903 (1969); P. S. Engel and C. Steel, *Acc. Chem. Res.*, **6**, 275 (1973).
- (14) R. D. Small, Jr., and J. C. Scalano, *Chem. Phys. Lett.*, **50**, 431 (1977).
- (15) It is interesting to compare this value with the values determined by P. Dowd and M. Chow (*J. Am. Chem. Soc.*, **99**, 6438, 1977) for the ring closure of trimethylenemethane. Depending on the matrix and concentration they found log *A* to range from 7.7 to 9.9.
- (16) For a review on tunneling see E. F. Caldin, *Chem. Rev.*, **69**, 135 (1969).
- (17) P. S. Engel, J. L. Wood, J. A. Sweet, and J. L. Margrave, *J. Am. Chem. Soc.*, **96**, 2381 (1974).
- (18) S. Chang, D. McNally, S. S. Tebrany, M. J. Hickey, and R. H. Bold, *J. Am. Chem. Soc.*, **92**, 3109 (1970).
- (19) J. P. Chesick, *J. Am. Chem. Soc.*, **84**, 3250 (1962).
- (20) H. E. O'Neal and S. W. Benson, *Int. J. Chem. Kinet.*, **2**, 423 (1970).
- (21) P. G. Gassman and K. T. Mansfield, *Org. Synth.*, **49**, 1 (1969).
- (22) W. Roth and M. Martin, *Justus Liebigs Ann. Chem.*, **702**, 1 (1967).
- (23) W. Grimme and W. von E. Doering, *Ber.*, **106**, 1765 (1973).
- (24) R. S. Rouse and W. E. Tyler, III, *J. Org. Chem.*, **26**, 3525 (1961).
- (25) R. C. Cookson, S. S. Grupte, I. D. R. Stevens, and C. T. Watts, *Org. Synth.*, **51**, 121 (1971).
- (26) S. W. Cohen, R. Zand, and C. Steel, *J. Am. Chem. Soc.*, **83**, 2895 (1961).
- (27) S. McLean and P. Haynes, *Tetrahedron*, **21**, 2313 (1965).
- (28) See also W. T. Ford, *J. Org. Chem.*, **36**, 3979 (1971); R. M. Acheson and R. Robinson, *J. Chem. Soc.*, 1127 (1952).
- (29) P. E. Eaton and R. A. Hudson, *J. Am. Chem. Soc.*, **87**, 2769 (1965); R. A. Hudson, Ph.D. Thesis, University of Chicago, 1966.

Matrix Effect on the Photochemistry of Cyclopropyl Ketones. Photochemistry of the Triplet State of 2-Spirocyclopropyl-1-indanone at 77 K

Rafik O. Loutfy* and Peter Yates*

Contribution from the Xerox Research Centre of Canada, Mississauga, Ontario, Canada L5L 1J9, and the Department of Chemistry, University of Toronto, Ontario, Canada M5S 1A1. Received September 11, 1978

Abstract: The photochemistry of 2-spirocyclopropyl-1-indanone (spiro[cyclopropane-1,2'-[2*H*]inden]-1'(3'*H*)-one, **6**) was investigated in solution and in glass matrices at 77 K. Irradiation of **6** in methanol or benzene solution led to negligible reaction, while irradiation in methylcyclohexane or ethanol/methanol glasses at 77 K gave (*E*)-2-ethylidene-1-indanone. The decrease in the phosphorescence emission as a function of irradiation time and the quenching of both product formation and phosphorescence by piperylene indicated that the photoproduct is formed exclusively from the $^3n,\pi^*$ state. The rate of disappearance of **6** was estimated from the change of the phosphorescence spectrum with time. This rate of disappearance during photolysis at 77 K was correlated with the incident light intensity and the process was found to be monophotonic. The luminescence of 2-spirocyclopropyl-1-indanone appears as multiplet phosphorescence with at least two components in methylcyclohexane, ethanol/methanol, or poly(methyl methacrylate) glasses at 77 K. In isopentane, on the other hand, the low-energy bands greatly predominated. These observations are attributed to emission from n,π^* triplets held in various conformations.

Introduction

The photochemical conversion of simple cyclopropyl ketones to propenyl ketones in the gas phase has been observed to occur from high vibrational levels of the singlet excited state.¹ Photoepimerization of cyclopropyl substituents via π^* -assisted cyclopropane fission is also a well-established process,² occurring primarily from the triplet excited state. These trans-

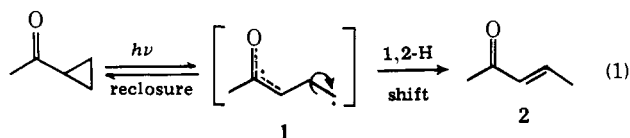

formations are accommodated mechanistically by invoking a biradical intermediate (**1**) as illustrated in eq 1. The biradical **1** can reclose to a cyclopropane with or without inversion of configuration at the radical centers or it can undergo a 1,2-hydrogen shift to give the conjugated acyclic ketone **2**.

The incorporation of the carbonyl group into a cyclic system as in spiro[2.4]heptan-4-one (**3**) can change the course of the

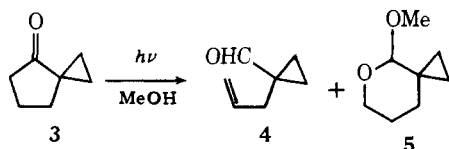

photochemical reaction. Thus Crandall and Seidewand³ showed that irradiation of **3** in methanol gave primary photoproducts **4** and **5** resulting not from isomerization of the cyclopropyl ring, but rather from α -cleavage at the other side of the carbonyl group. In spite of the fact that the geometry of the α -spirocyclopropyl and the carbonyl moieties might be expected to be optimal for interaction in **3**, no product from cyclopropyl ring fission was observed. Turro and co-workers^{4,5} have made similar observations and have shown from rate and quantum yield measurements that the α -spirocyclopropyl substituent enhances the ring expansion of cyclopentanone. This was attributed to resonance stabilization of the acyl radical portion of the intermediate biradical leading to closer proximity of the alkyl radical center and the carbonyl oxygen.⁶ The ring expansion was shown to occur exclusively from the triplet excited state.⁴ Again no photoproduct due to cyclopropyl ring fission was observed.⁷

In the present study we have examined the photochemistry and spectroscopy of 2-spirocyclopropyl-1-indanone (**6**) in solution and in glass matrices. The objectives of the work were (1) to establish whether cyclopropyl ring fission will occur if α -cleavage at the other side of the carbonyl group is made difficult, (2) to assess the importance of the nature of the triplet state (n,π^* vs. π,π^*) in the π^* -assisted cyclopropyl fission, and (3) to determine the effect of matrix isolation and low-temperature photolysis on the course of the chemical reaction.